

Battery Parallel Connection Operation Guide

Precautions

When performing battery parallel connection operations, it is essential to strictly adhere to the following precautions to ensure operational safety and proper equipment function:

1. **Parallel Limitation:** The number of parallel batteries must not exceed 4 stacks.
2. **Communication Cable:** Only the master battery requires a communication cable connection to the inverter.
3. **Cable Specification:** Prepare at least 6mm² DC cable.
4. **Connector Requirement:** An MC4 parallel connector is required. Alternatively, you can place an order in advance, and we can provide a dedicated parallel connection harness.

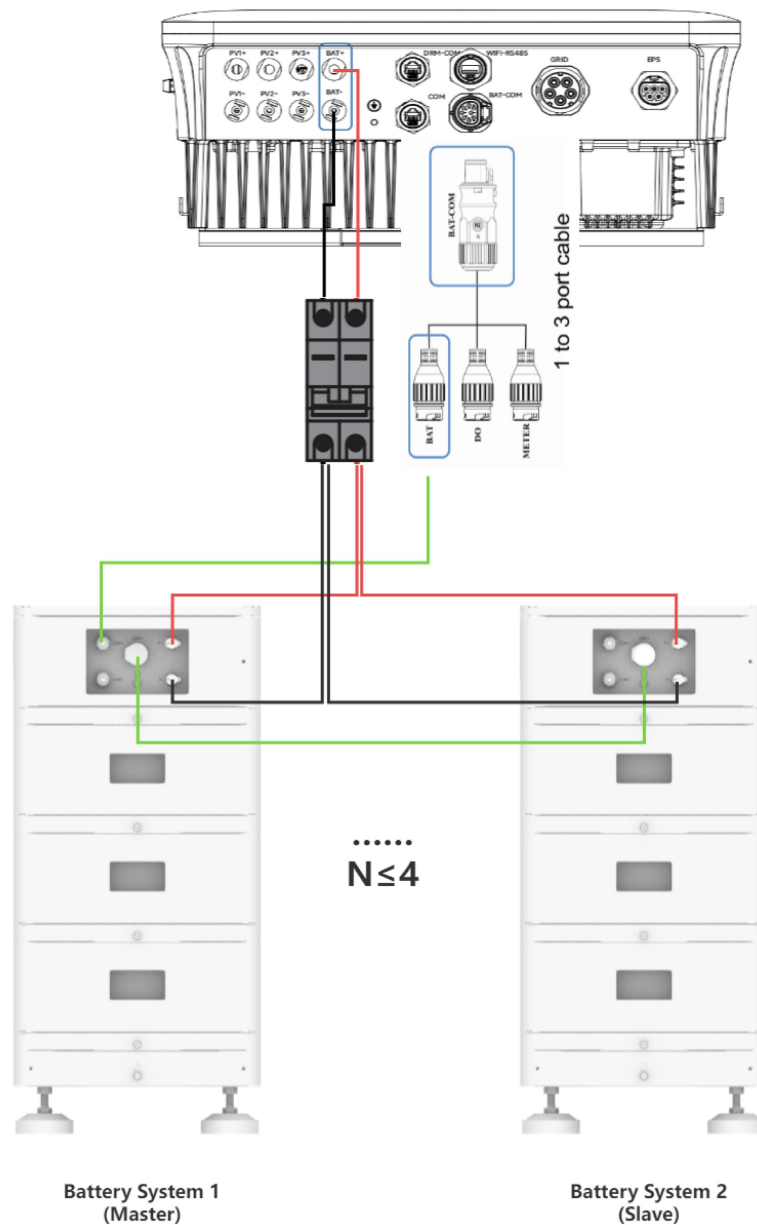

Operation Guide

Scenario 1: Two Sets of Brand New Battery Modules and BMS (If some modules or BMS are used, proceed to Scenario 2)

When both sets of battery modules and BMS are brand new and unused, follow these steps:

1. **Establish Communication Between Batteries:** As shown in the diagram, connect pin 5 (CAN_H) and pin 6 (CAN_L) of the COM3 port on the right side of the BMS of the two stacked batteries. This connection establishes communication between the parallel batteries.

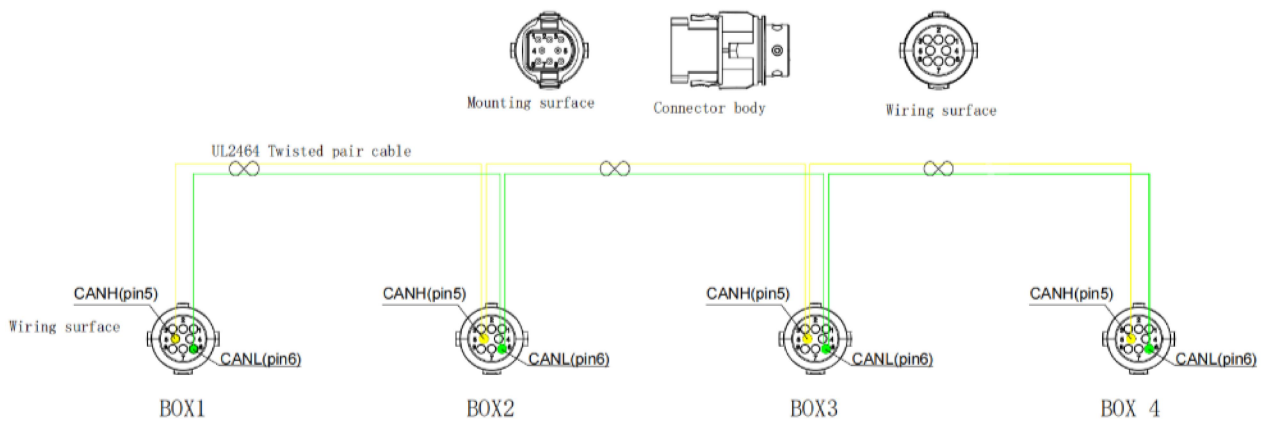

2. **Establish Communication with the Inverter:** Connect the COM1 port of the master battery's BMS to the inverter's battery communication port. This connection enables the inverter to accurately monitor and manage the battery status.

3. **Positive and Negative Pole Wiring:** After paralleling the positive and negative poles of the two sets of batteries using a MC4 parallel connector, connect them to the inverter.

4. **Pre-power-on Inspection:** Before powering on, thoroughly inspect all connections to ensure they are secure and correctly connected to prevent equipment damage or safety accidents due to wiring issues.

Scenario 2: Partially Used Modules or BMS

If some battery modules or BMS have been used, follow these steps:

1. **Charging Batteries:** Connect the two sets of stacked batteries to the inverter respectively, and fully charge them to 100%.

2. **Battery standstill:** After the two sets of batteries are fully charged to 100%, switch off the battery circuit breakers and leave the batteries to stand for 2 hours.

3. **Voltage Check:** After the period, use a multimeter to measure the total voltage of the positive and negative poles on the right side of the BMS of both battery sets. If the voltage difference is less than 2V, proceed to the next step; if not, continue charging until the voltage difference is less than 2V.

4. **Establish Communication Between Batteries:** Once the voltage difference is below 2V, connect pin 5

(CAN_H) and pin 6 (CAN_L) of the COM3 port on the right side of the BMS of both battery stacks to establish communication between the parallel batteries.

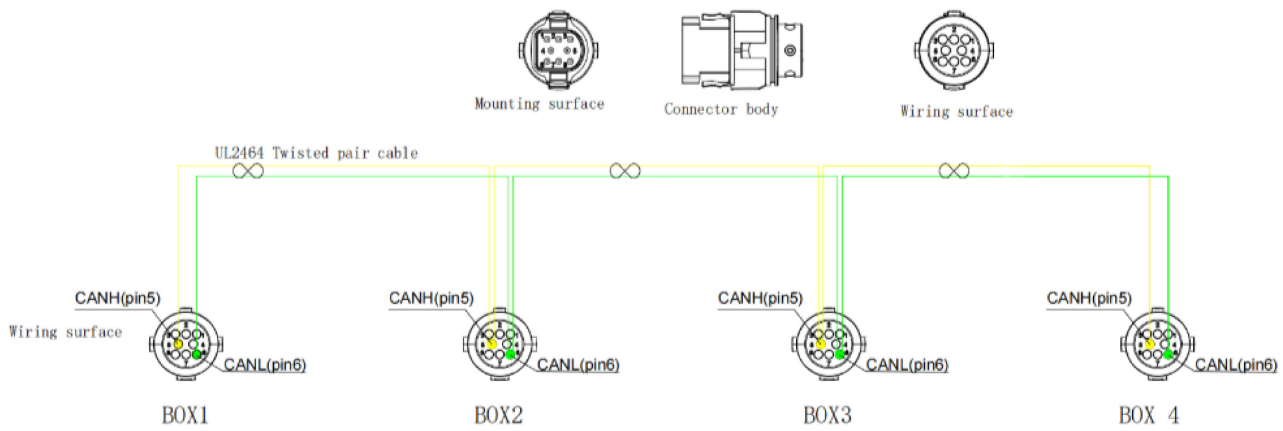

5. **Establish Communication with the Inverter:** Connect the COM1 port of the master battery's BMS to the inverter's battery communication port to establish communication between the inverter and the battery.
6. **Positive and Negative Pole Wiring:** After connecting the positive and negative poles of both battery sets to MC4 connectors, link them to the corresponding terminals on the inverter.
7. **Pre-power-on Inspection:** Before powering on, thoroughly inspect all connections to ensure they are secure and correctly connected to prevent equipment damage or safety accidents due to wiring issues.